

INSTALLATION INSTRUCTIONS

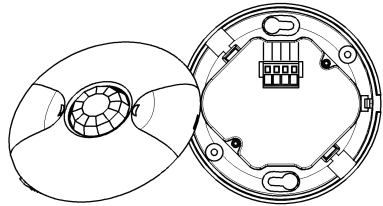

MPC-50L

360° Passive Infrared Low Voltage Occupancy Sensor



SPECIFICATIONS

Voltage.....	24VDC
Current Consumption.....	9mA
Power Supply (Not included).....	MPP-24 Power Packs
Operating Temperature.....	32° to 131°F (0° to 55°C)
Adjustable Light Level.....	10FC-150FC
Adjustable Time Delay.....	5 sec.-30min (DIP switch)
Walk-Through Mode.....	3 minutes if no activity after 30 sec.
Test Mode.....	5 sec. upon initial power-up or DIP switch reset

PIR Coverage:	
Sensitivity Adjustment.....	50% or 100% (DIP switch)
Coverage.....	Up to 1200 ft ²

DESCRIPTION

The MPC-50L 360° occupancy sensor uses advanced PIR technology to turn on the lights when motion is detected and keep the lights on when movement is present. The sensor will automatically turn off the lights if no movement is detected within the amount of time selected in the time delay. The built in "walk-through" mode could offer extra energy saving and switch the lights off in 3 minutes when the room becomes unoccupied after the first 30 seconds of the initial detection.

The MPC-50L operates on 24V powered by MPP-24 Power Packs.

COVERAGE

The MPC-50L provides a 360° coverage pattern, up to 1200 square feet. The diagram below shows the range of detection with the sensor mounted at a height of 8 feet. The sensor is designed to detect a heat-emitted movements across its range of view. Obstructions and low levels of movements may hinder the level of detection.

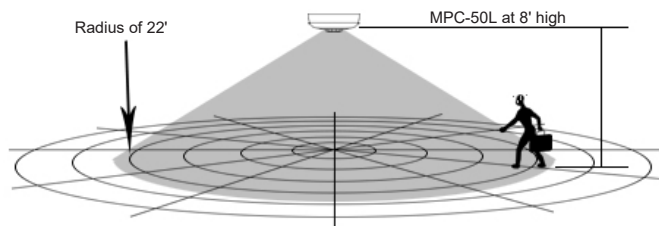

Location: Device should be mounted in a location free of obstruction from furniture, plants, walls and vibration (see Figure 1). The sensor must be mounted a minimum of 4 ft. away from any air vents. Avoid mounting the sensor close to heat source. When mounting directly to a ceiling light fixture, the lens of the sensor must be below the lowest point of the fixture.

MPC-50L is designed for a ceiling height of about 8-10 feet. Because of the umbrella shaped coverage pattern, mounting above or below the recommended height could reduce coverage range and sensitivity. Another important thing to note is that it's not necessary to have occupancy sensor coverage on every square inch of space in any particular room. These spaces generally have many people moving around in them.

The best location to install multiple MPC-50L is usually in the walkways of an open office space (see Figure 2).

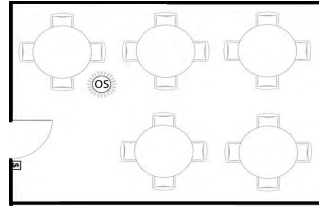

Figure 1

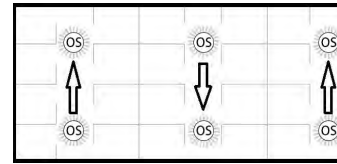

Figure 2

Helpful hints:

- Make sure that the sensor's view of the entrance will not be blocked by the door when it is open.
- Program a longer time out to avoid the lights constantly turning on/off.
- Do not mount sensors close to air vents.
- Cover the main walkways.
- Try to avoid having the sensor looking out the door of the space

Open Office or Classroom Area Coverage:

- To get complete coverage in an open office area, install multiple sensors so that there is at least 15% overlap with each adjacent sensor's coverage area.
- The sensors should cover the primary occupant's desk, the entrance and any other areas with heavy traffic.

WARNING

Turn the POWER OFF at the circuit breaker before installing the sensor

Read and understand these instructions before installing. This device is intended for installation in accordance with the National Electric Code and local regulations. It is recommended that a qualified electrician performs this installation. Make sure to turn off the circuit breaker or fuse(s) and make sure power is off before wiring the device. Use copper wire only, or equivalent.

WIRING DIRECTIONS

The MPC-50L requires the MPP-24 power pack (not included). Each power pack supports up to 6 sensors. When using more than 6 sensors, additional power packs are required.

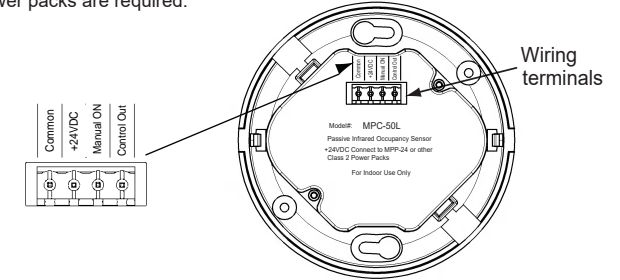

Connect the low voltage:

- Connect RED wire from power pack to the +24V terminal on the sensor.
- Connect BLACK wire from power pack to Common terminal on the sensor.
- Connect BLUE wire from power pack to Control Out terminal on sensor.

To add a MANUAL SWITCH such as the Momentary Toggle Switch:

- Connect Gray wire on Power pack to 24VDC on sensor.
- Connect one wire from the momentary switch to the Common terminal on sensor, and the other wire from the momentary switch to the Manual On terminal on sensor.

LIGHT LEVEL ADJUSTMENT

The sensor may be adjusted to operate at the desired level of ambient light.

To do so, turn the dial to point the arrow toward the "-" sign for sensor to detect motion and operate during low light or no light. Point the arrow toward the "+" sign for sensor to operate when there's more light in the area or even during daylight.

NOTE: The light level is adjustable only when the time delay is set at or above 30 seconds.

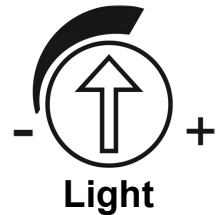

SENSOR ADJUSTMENT

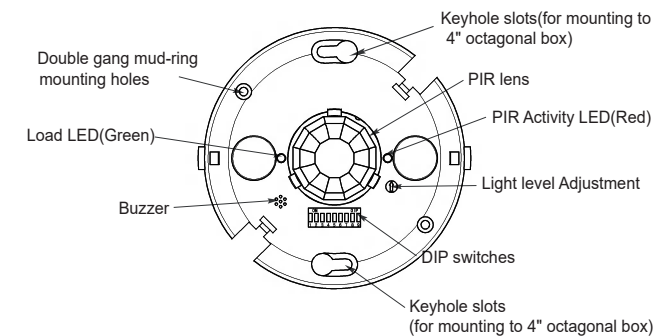

INSTALLATION

Using an Octagonal J-box (not included)

1. Pull the low voltage wires from the power pack into the J-Box through the conduit knockout.
2. Connect the low voltage wires to the appropriate terminals on the sensor.
3. Loosen the appliance mounting screws attached to the J-Box.
4. Align the sensor to the J-Box so that the mounting screws on the box match the key holes on the sensor's rear housing.
5. Push the sensor up into the J-Box and twist it so that the mounting screws are seated in the keyhole slots.
6. Tighten the two screws to secure the sensor to the J-Box.
7. Snap on the front cover onto the sensor.

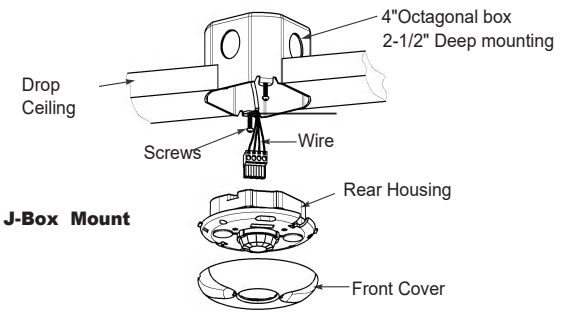

Mounting Option (not included): Auxiliary Mounting Adapter for Ceiling Sensor

Model	Description
MPC-A	The Auxiliary Mounting Adapter allows you to mount the ceiling sensor onto boxes such as 4" and 5" square junction box.

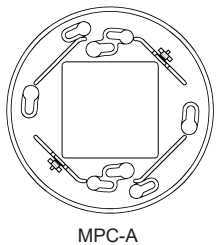

TESTING OCCUPANCY SENSOR

To enter Test Mode set DIP switches 2,3,4 to the OFF position, then toggle DIP switch #3 ON and back to the OFF position. This provides a 5 minute test period. During the test period, the Time Delay is only 5 seconds.

1. Ensure the PIR Activity is enabled, red LED flashes, Hold ON mode are OFF (DIP 9 switch OFF) and PIR Sensitivity is set to MAX (DIP switch 1 ON).
2. Ensure the Time Delay is set for Test Mode* using the "5 seconds/ Autose" setting. (DIP switches 2, 3 & 4 are OFF).
3. Ensure that the Light Level is at default (maximum). See the Light Level Feature section of this document for instructions.
4. Remain still. The red LED should not flash. The green LED and load are ON, and the lights should turn off after 5 seconds. (If not, see "Troubleshooting.")
5. Move in the front of coverage area. The lights should turn on automatically. When testing and adjustment is complete, reset DIP Switches and Light Level to the desired settings, and put the front cover back on the sensor.

Note: There is a 40-second warm-up period when power is first applied. Use a small screwdriver to open the front cover and make changes to the settings. The pre-set time delay is Test mode and light level is set at maximum

DIP SWITCH SETTING

The MPC-50L has 9 DIP switches under the cover. They are used to set sensitivity, time delay, walk through mode, vacancy mode, audible, visual alarm and Hold ON feature settings.

Sensitivity	1	Time Delay	2	3	4	Audible Alert	7
50%	↓	5 Sec/Autose	↓	↓	↓	Disabled	↓
100%	↑	30 Seconds	↓	↓	↓	Enabled	↑
Walk Through	5	5 Minutes	↓	↓	↓	Visible Alert	8
Disabled	↓	10 Minutes	↓	↓	↓	Disabled	↓
Enabled	↑	15 Minutes	↑	↑	↑	Enabled	↑
Vacancy	6	20 Minutes	↑	↑	↑	Hold ON	9
Disabled	↓	25 Minutes	↑	↑	↑	Disabled	↓
Enabled	↑	30 Minutes	↑	↑	↑	Enabled	↑

↓=OFF ↑=ON ◀=Factory Setting

Sensitivity setting: DIP switch 1

- 50% -This setting will decrease the amount of area the sensor will cover to half the range
- 100% , the maximum range of sensor's coverage is 1200 square feet, see "coverage pattern"

Time delay: DIP switch 2,3,4

The time delay is set with Dip switches 2, 3 and 4, from 15 seconds to 30 minutes. When there is no movement detected by sensor, the lights will automatically turn off after the selected time delay has expired.

Autose feature record and analyze the occupancy patterns and provide optimal time delay from 5s to 30 minutes. AutoSet feature starts immediately and continually update their time to ensure that the sensor provide all you need.

Walk-through mode: Switch 5

With Walk-through mode enabled, the sensor turns lights off automatically in three minutes when no movement is continued after first 30 seconds. Time delay has to be set to 5-minutes or more in order to use walk-through feature.

Vacancy Mode: Switch 6

"Manual ON" function is achieved by using a momentary switch, such as model number 91245 (not included) from Enerlites. The switch may be connected to the sensor's "Manual ON" and "Common" or with Gray wire from power pack and +24VDC on sensor. The load can operate by pressing the momentary switch. The operation of the sensor connected to manual switch depends on the DIP switch 6 setting.

1. Vacancy ON: In this mode, press the momentary switch to turn on the load. Movement will keep the load on.
2. Automatic On: In this mode, the sensor will turn the load ON automatically when motion is detected.

A momentary switch provides the following additional functionality:

- The light can be turned on manually by pressing the momentary switch at any time. The lights will stay on as long as movement is detected. If no movement is detected when the programmed time delay has expired, the lights will turn off automatically.
- Turn the lights OFF manually.
 - a. When the lights are turned OFF by the manual switch, the lights will stay off until the time delay has expired. After the time delay has expired, the sensor will switch back to Automatic ON mode.
 - b. Pressing the manual switch again will turn the lights on and the sensor will be switched to the Automatic ON mode.

Audible Alert: Switch 7

When this feature is enabled you can hear a "tick" from the buzzer 1 minute before the time delay expires, again at 30 seconds, and again at 10 seconds, indicate that the lights are about to turn off automatically.

Visible Alert: Switch 8

When this feature is enabled the lights attached to the load will flash once as reminder, 1 minute before the time delay expires.

Hold ON: Switch 9

This is the OVERRIDE setting. Set DIP switch 9 to the ON position to override. The green and red LEDs will be lit and will stay on for the duration of the override. This bypasses the light level, occupancy detection, and the manual ON functions will be invalid.

TROUBLESHOOTING

NOTE: There is a 40 seconds warm-up time at initial power-up. LED does not blink:

1. Check that the circuit breaker has been turned back on.
2. Make sure that the PIR Sensitivity is set for 100% (DIP switch 1 ON).
3. Check the wire connection between all sensors and power pack.
4. Check for 24V input to the sensor.
 - a. If 24V is present, replace the sensor.
 - b. If 24V is not present, check that high voltage is present to power pack. If it is, replace power pack.

LED blinks but lights do not turn ON:

1. Check the "Light" setting. If the arrow is pointed to the "-"position, the area needs to be dark enough for the sensor to operate. Cover the light sensor lens to simulate darkness. If the light turns ON, the light level setting needs to be adjusted.
2. Make sure the wires are connected and bulbs are working.
3. Check for obstructions in the lens cover.
4. Make sure that power to the sensor has been ON continuously for at least one minute. Wait for the warm-up period to end.
5. Check for 24VDC at the power pack.

Lights do not turn OFF automatically:

1. If there is no motion from people or equipment in the sensor's view but the LED blinks, look for any nearby source of infrared energy (heat) in motion, such as turbulent air from a heating or cooling supply.
 - a. Mount the sensor so that its lens is below the edge of the fixture and does not directly view the lamps.
 - b. Move the air supply away from the sensor, or move the sensor.
2. Verify the time delay settings in switches 2-4. Ensure that the time delay is set to the desired delay and that there is no movement within the sensor's view for that time period.
3. Check sensor wire connections.
 - a. Disconnect power pack's blue wire:
 - b. If the lights do not turn off, replace power pack.
 - c. If the lights turn off, the problem may be in the sensor. To check:
 - i. Reconnect the blue wire.
 - ii. Turn sensitivity and time delay to minimum and test the functionality. If the lights turn off, the sensor is working properly.

WARRANTY INFORMATION

This device is warranted to be free of material and workmanship defects for 2 years from the date of purchase. Original receipt or proof of purchase from an authorized retailer must be presented upon warranty claim. ALL claims must be verified and approved by Enerlites, Inc. Warranties from other Enerlites products may vary. This warranty is nontransferable and does not cover normal wear and tear or any malfunction, failure, or defect resulting from misuse, abuse, neglect, alteration, modification, or improper installation. To the fullest extent permitted by the applicable state law, Enerlites shall not be liable to the purchaser or end user customer of Enerlites products for direct, indirect, incidental, or consequential damages even if Enerlites has been advised of the possibility of such damages. Enerlites' total liability under this or any other warranty, express or implied, is limited to repair, replacement or refund. Repair, replacement or refund are the sole and exclusive remedies for breach of warranty or any other legal theory.



© 2016 Enerlites Inc.
CA, U.S.A.
WWW.ENERLITES.COM
0205160001