

Project: _____
 Part#: _____
 Type: _____

Linear LED High Bay

The EnVision LED Linear High Bay series is offered in different lumen packages, lengths, and lenses. EnVision makes it easy: add emergency back ups, motion sensors, choose between a frosted or clear lens, add a wire guard, and more. Each fixture comes standard with a suspension kit and hooks for easy install.

Applications:

- Warehouse lighting
- Industrial lighting
- High ceiling lighting

Product Information:

- Replace existing fixtures or use in new construction
- 0-10V dimmable makes it easy to add controls
- Uniformed distribution of light
- High lumen per watt helps increase energy savings
- Average life (L70) of 70,000 hours with the integration of Epistar 2835 LED Chips
- 5 Year Limited Warranty (10 year available)

Detail Specifications

- Operating temperature -4 -- + 122 F°
- PF >0.9 /50/60Hz
- Beam Angle: 120°

Why pick the EnVision High Bay?:

- Each high bay is tested for 120 hours before being packed and shipped
- Several optional customizable specs available
- Internal motion sensor ability adds nice finish

LED - LHB	Size/Watts	Lens/Finish	Sensor	Color	Voltage	ACCS	Emergency	Warranty
1	2	3	4	5	6	7	8	9

1 Product

LED-LHB LED Linear High Bay

2 Watts

2FT-110W	13,750 (frost) 15,400 (clear)	F-W Frosted C-W Clear	(blank) No Sensor	50K 5000k	(blank) 120/277V HV 200/480V	(blank) Chain Mount SM Surface Mount PM Pendant Mount WG Wire Guard	EMB Emergency Backup (90 mins)	(blank) 5 year lmtd. 10YR 10 year lmtd.
2FT-165W	20,625 (frost) 23,100 (clear)	White Finish	MS Motion Sensor					
4FT-220W	27,500 (frost) 30,800 (clear)							

3 Lens

4 Sensor

5 Color

6 Voltage

7 Accessories optional

8 Emergency optional

9 Warranty

DIMENSIONS

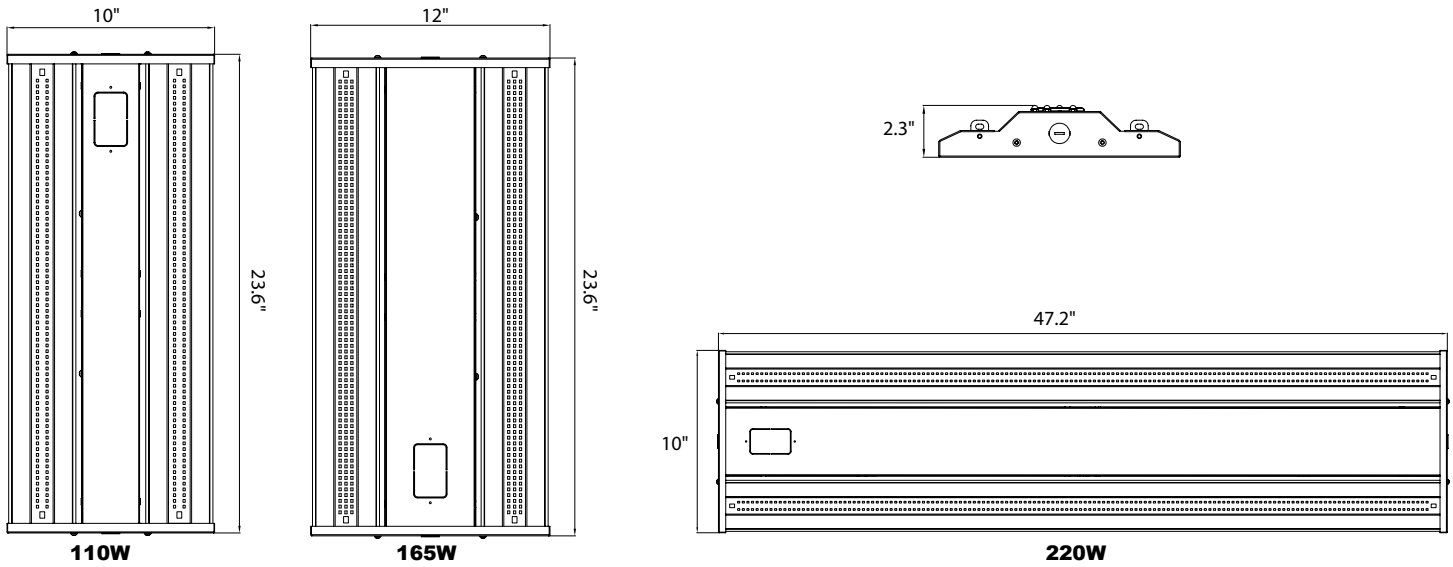

FEATURES

Reliable LED Chips

Philips 3030 LED chips for longevity, consistent color, and reliability

High Quality Lens

Long lasting lens that does not yellow after short period of use

Side Knockouts

Add optional accessories including emergency back ups

Integrated Sensor

Motion sensor doesn't stick out of the fixture, EnVision has created the perfect spot for sensors

Easy Open

Easily open the side frame to change from frosted to clear lens in 60 seconds

